

SERIES 2400 CONTRACTOR LIFT

A super compact, versatile lift at a great price.

APPLICATIONS

- Super Compact 12 ft (3.7 m) & 16 ft (4.9 m) lifts
- 450 lbs (200 kg) lift capacity
- One piece construction - no loose pieces
- Easily portable for one person operation
- Fits most SUVs and vans
- 12' 11-3/4" & 16' 11-3/8" heights when forks reversed
- Perfect lift for HVAC contractors, electrical contractors, industrial maintenance, steel erectors, and facility management
- Double row casters are (4) 3" (7.5 cm) casters permit easy handling of heavy loads, swivel independently, lockable to insure safety, and allows for multi-directional positioning of lift
- Inside-mast cable feed allows cable to feed inside mast, removed from operator for safety - similar to the 2000 & 2100 Series lifts
- Ideal for compact storage - no tools or loose hardware to worry about. Leg lock mechanism releases with plunger pin and slides on base leg.

WINCH

COFFEE GRINDER STYLE WINCH FEATURES AUTO-BRAKING AND DETACH-ABLE WINCH HANDLES

ROLLER WHEELS

HANDY WHEELS LOCATED TO EASE ROLLING INTO VEHICLES FOR TRANSPORTATION

8" (20 CM) NON-MARRING WHEELS

PULLEY GUARDS

CONTAINS LOAD CABLE AND LINE CANNOT COME OFF

HANDLE

USE CONVENIENT HANDLE FOR "HAND TRUCK" MOBILITY AND TO POSITION LIFT AT POINT OF USE

REVERSIBLE FORKS

TWO PLUNGER PINS PERMIT QUICK RELEASE OF FORKS. FORKS MAY BE REMOVED FOR STORAGE OR REVERSED FOR ADDED HEIGHT

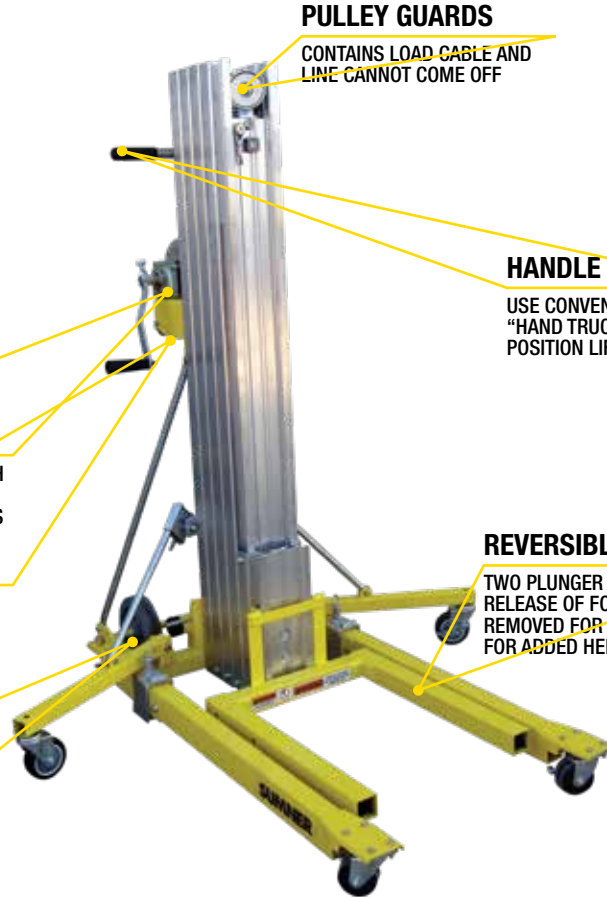

PART #	DESCRIPTION	HEIGHT MAX (FORKS UP)	HEIGHT MAX (FORKS DOWN)	LIFT CAPACITY	HEIGHT STOWED	LENGTH STOWED	LENGTH OPERATING	WIDTH STOWED	WIDTH MAX	WINCH CRANKS	BASIC WEIGHT
784750	2412 Contractor Lift	12' 11-3/4" (4.0 m)	12' (3.7 m)	450 lbs (200 kg)	62-3/4" (159.4 cm)	23" (58.4 cm)	48" (121.9 cm)	26-3/8" (67.1 cm)	26-3/8" (67.1 cm)	8 per ft (24 per m)	195 lbs (88.5 kg)
784751	2416 Contractor Lift	16' 11-3/8" (5.2 m)	15' 11-5/8" (4.9 m)	450 lbs (200 kg)	62-3/4" (159.4 cm)	23" (58.4 cm)	48" (121.9 cm)	26-3/8" (67.1 cm)	55-1/4" (140.3 cm)	8 per ft (24 per m)	243 lbs (110.2 kg)



SERIES 2400 CONTRACTOR LIFT ACCESSORIES



FORK EXTENSION (# 784695)

With the push of a button, forks may be extended from 23-1/4" (59.2 cm) to 29-7/16" (75.7 cm). When using the fork extensions the weight capacity reduces to 200 lbs (90 kg), as is clearly marked on the extended forks. A second button returns the extension for storage inside forks.

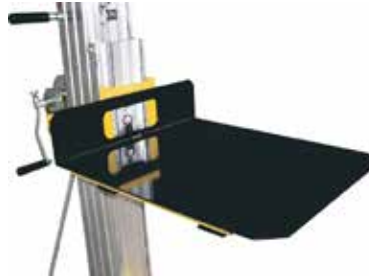

STEEL TRAY (# 784320)

24" x 24" (61 x 71 cm) steel tray slides onto forks.



PIPE CRADLE (# 783705)

Great for air ducts or other HVAC applications. Slides over forks. Packaged two per set.

CABLE BRAKE (# 784755)

Each mast and carriage can have a factory installed, gravity actuated safety brake which holds loads in place in the event cable goes slack.

